

ecolite®

Innovación™
que ilumina



FICHA
TÉCNICA
REFLECTOR SOLAR LED

ecolite®

Reflector Solar LED

Ref. FLOSUN100



GARANTÍA
2 AÑOS

INFORMACIÓN DEL PRODUCTO

POTENCIA	100W
CANTIDAD DE CHIP	45 Und
TIPO DE LED	SMD 5050
POTENCIA PANEL SOLAR	10W
VOLTAJE PANEL SOLAR	5v
TIPO DE PANEL	Monocrystalino
BATERÍA	3.2V/10AH LiPo4
TIEMPO DE CARGA	5-6h @ 40.000Lux
AUTONOMIA	10-12 h
TEMP. DE COLOR	RGB + W
IRC	>70Ra
FLUJO LUMINOSO INICIAL	1.400Lm
CHASIS	Aluminio
COLOR DE CHASIS	Gris
GRADO DE PROTECCIÓN	IP65 IK08 (Luminaria)
TIPO DE MONTAJE	Sobrepuesto
TEMP. DE TRABAJO	-10°C ~ + 45°C

ESQUEMA

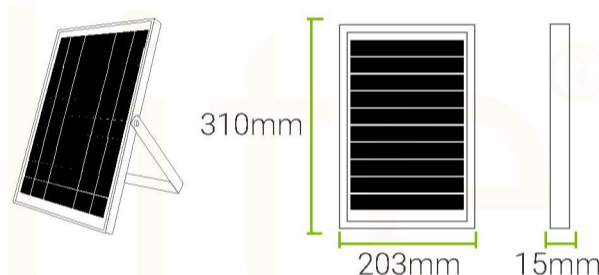
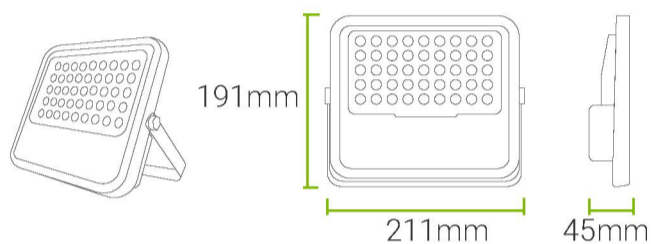

Largo de Cable
Largo: 2 Metros

CARACTERÍSTICAS

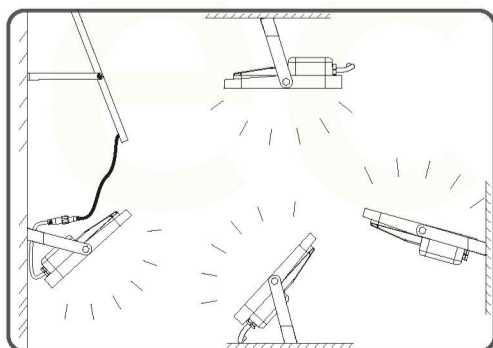
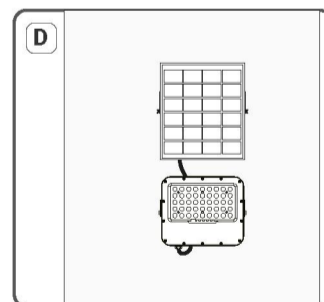
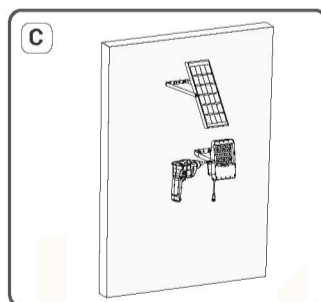
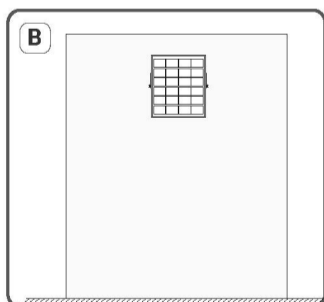
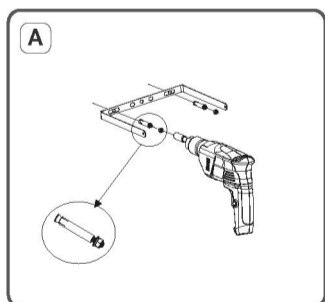

Accesorios

